

NH₃
AMMONIA
R717

HFC
HFO
CFC

R718
WATER



Liquid Level Sensor HBLT-Wire



NH₃
AMMONIA
R717

HFC
HFO
CFC

R718
WATER

Our Liquid Level Sensor is engineered specifically to measure refrigerant levels in traditional stationary systems like vessels, receivers, or accumulators. Utilizing the capacitive principle, the sensors are optimized and calibrated to suit various types of liquids and operating environments.



The HBLT-Wire is an all-in-one length probe featuring a flexible sensor wire for on-the-job length adjustability, ensuring versatility across various applications. With an output signal of 4-20 mA proportional to liquid level from 0% to 100%, it's perfect for refrigeration systems facing high pressures and extreme temperatures.

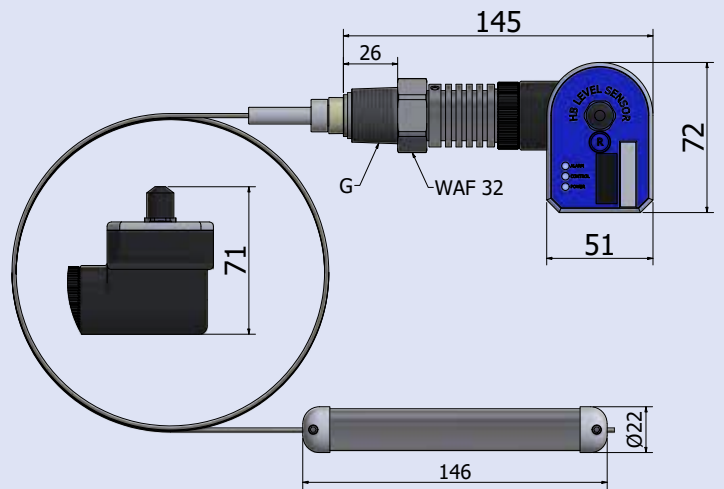

This sensor can be conveniently cut to size, with measurement lengths ranging from 250 mm to 6000 mm, and is compatible with most refrigerants. Its longevity and reliability are evidenced by over a decade of market presence, during which it has undergone continuous improvement. The electronic unit mirrors that of the rigid probes, ensuring consistent performance.

With no bottom dead zone, this capacitive sensor can measure to the bottom of a vessel if necessary, making it ideal for measuring liquid levels in gas or air.

	Wire Sensor	Rigid Probe
Suited for Ammonia, HFC, HFO, CFC and Water	Yes	Yes
Suited for CO2, Propane, Butane, Isobutane	No	Yes
Suited for oil and fuels	No	Yes
Suited for not mixed fluids (Ammonia and oil in gas)	No	No
Available with direct valve controller	Yes	Yes
Accuracy	High	Very high
Split design (replaceable electronic unit)	Yes	Yes
Adjustable length	Yes	No

Specifications	
Suited for	Ammonia, HFC, HFO, CFC and water
Power supply	24V AC/DC ±10%
Power consumption	600mA
Connection	M12 5-pin connector
Output	4-20 mA
Control (option)	1A
Ambient temperature	-30°C to 50°C (-22°F to 122°F)
Liquid temperature	-60°C to 60°C (-76°F to 140°F)
Max pressure	100 bar (1450 psi)
Protection class electronic unit	IP65
Thread connection	¾" NPT or BSPP
Scope of supply	Sensor 5m connection cable with plug USB M12 configuration cable
Sensor configuration	Free HB Tool
Sensor detection length	250 mm – 4000 mm (option 6000 mm)

Features and benefits

- Flexible sensor, which is adjustable to a length of 250 mm to 6000 mm.
- The sensor's split design makes it easy to install and service. The electronic part can be easily separated from the mechanical part by loosening the threaded union.
- Simple calibration for the specified length.
- It can be used for marine applications since measurement is not affected by contact with the standpipe's metal surface.
- Can measure Ammonia, water & HFC/HFO/CFC refrigerants.

Proven by the Industry

HB Products has made reliable and efficient sensors and switches for the cooling industry for over 25 years.

We know that refrigeration systems must remain up and running, and we make all our products with that requirement in mind. Therefore, we test new products in refrigeration systems or industrial applications before we add them to our product line. That way we can guarantee that your installation will run safely and efficiently.

All our products are developed and made in Denmark to ensure the highest standards of quality. We use local components widely in the production and have our own in-house QA to ensure that every item lives up to the highest standards.



HB Products A/S

Bøgekildevej 21

DK-8361 Hasselager

Phone +45 87476200

www.hbproducts.dk

We are dedicated to supplying switches and sensors for industrial applications.

We focus on refrigeration, but our sensors can be used in other industrial applications where robust and reliable sensors are called for.

Our sensors are developed and manufactured in Denmark. We mainly use local sourced parts to increase flexibility and reduce lead times.

All sensors and switches comply with EU directives and have earned the CE marking.