

Quick Guide for HBLT-W3-Wire

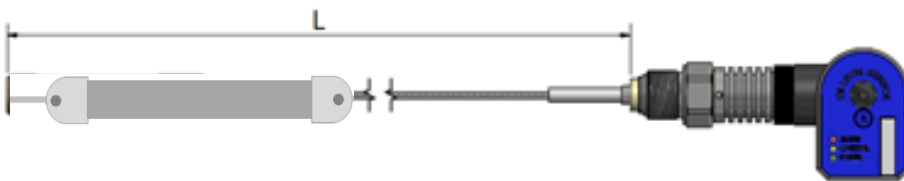

Level Sensor Installation adjusting the length and setup

1. Separate the electronic transmitter from the mechanical base.
2. Determine probe sensor wire length. The active length is shown on this picture



3. Cut the wire to the needed length and attach counterweight.

The sensor length is determined by standpipe length or tank height. Cut the insulated steel wire to desired measuring length with a wire cutter. The sensor will measure to the end of the wire without any dead zone. 25 mm (1") distance from wire end to the bottom is needed to make sure it is linear at the bottom.

The wire is passed through the counterweight and fixed by the 2 HEX screws. The free wire below the counterweight should be 10 to 50 mm (½" to 2")

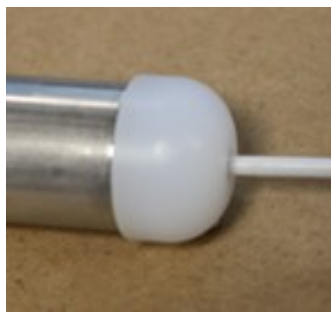
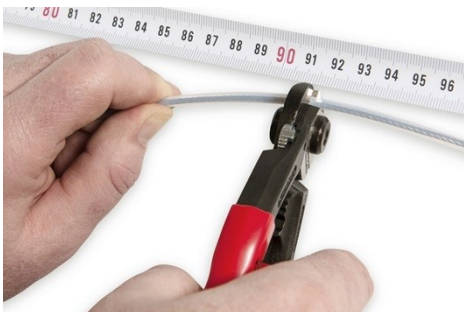

4. Use the M12 to USB-A programming cable to connect the sensor to the HB tool.

You find it here <https://www.hbproducts.dk/en/hb-tool> Or scan the code

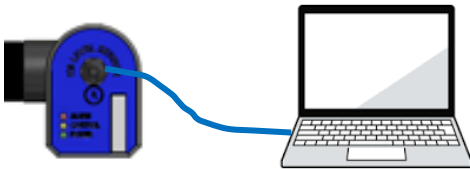

5. Open the tool and scan for sensor.

In the tool

Go to basic settings

Fill in the sensor length and the other fields specifying the mechanical type.

Adjust the filter time if needed

Optional setup an alarm or type in offsets

Click on save to sensor

The calibration is now calculated, and the setup is done.

The sensor needs to be installed in a metallic vessel before it can provide an output.

The sensor will deliver 4 mA when it is empty and 20 mA when full

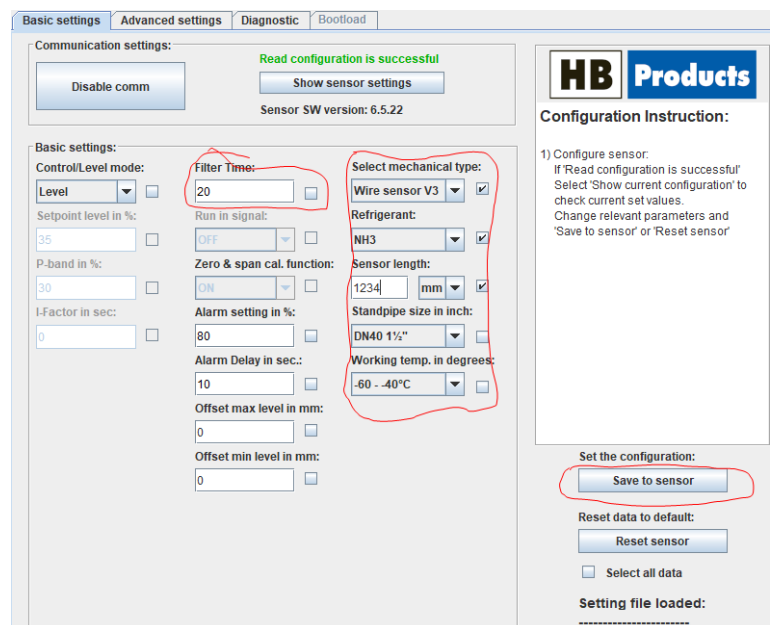

6. LED indication with 24V connection

LED Signal	ON/OFF/Frequency	Functionality
Green	Flash	In operation
	OFF	No supply voltage
Red	Flash	No connection to mechanical unit

25-03-2025

7. Installation

The mechanical part is installed in the system using liquid sealant or PTFE tape.

The electronic unit must be tightened firmly to secure good electrical connection – pliers can be used.

8. electrical connections

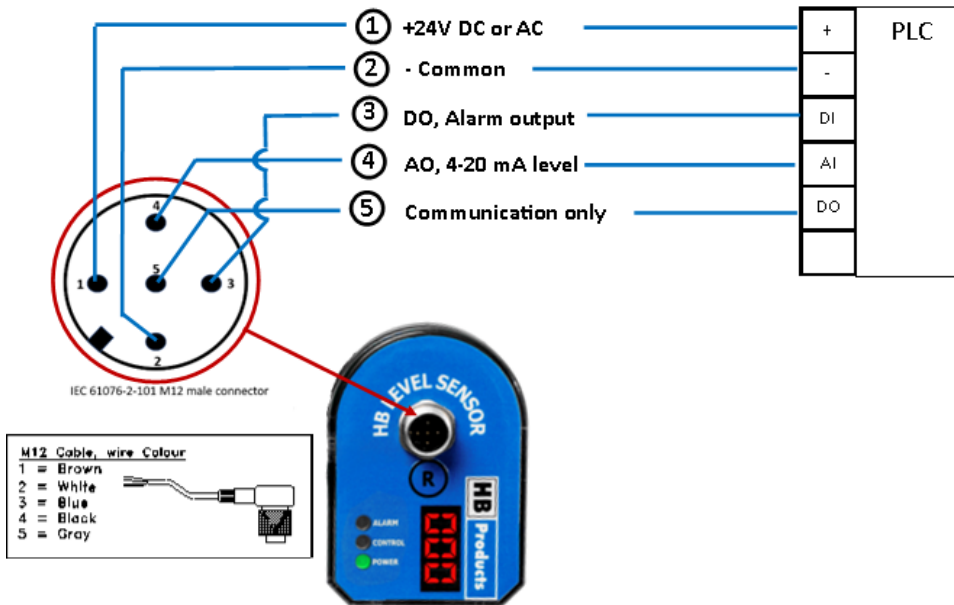

9. More information

A complete manual can be found here

<https://www.hbproducts.dk/en/exhibition-material/downloads/level-sensors/444-flexible-level-sensors-wire-sensors-delivered-from-december-2021-onwards-instruction-manual/file>

For any inquiries or further information, please don't hesitate to contact us at support@hbproducts.dk.

HB Products A/S
 Bøgekildevej 21
 DK-8361 Hasselager
 Phone: +45 87476200
www.hbproducts.dk