

Instruction manual

HBLT-A1 LIQUID LEVEL TRANSMITTER

for measuring liquid level
in refrigerant vessels



Contents

Introduction.....	2
Key features.....	2
Measuring principle.....	2
Function.....	2
Technical data.....	3
Design and function.....	3
Factory setting.....	4
Installation instruction.....	4
Electrical connection.....	4
Setting of refrigerant.....	4
Signal damping.....	5
Calibration.....	6
Adjusting the min and max calibration points.....	6
Reset to factory setting.....	7
LED indication.....	7
Ordering codes.....	8
Practical calibration hints.....	9
Check of sensor tube.....	11
Trouble shooting.....	12
Further information.....	12
Declaration of conformity (CE).....	13

Introduction

HBLT capacitive liquid level transmitters are used to measure liquid levels in refrigerant vessels.

The HBLT transmits an active 4-20 mA signal which is proportional to the liquid level.

4 mA when the transmitter does not register liquid and 20 mA when the entire transmitter is surrounded by liquid

The 4-20 mA signal from HBLT can be used in conjunction with a controller to control the liquid level.

Key features

- Plug and Play: no calibration required when installed on NH₃ systems
- Service friendly: electronic head and sensor tube can be separated without emptying the vessel.
- Damping of output signal.
- Improved calibration: range/signal output can be adapted to suit the actual application.
- LED Indication can be supplied with a LED Bargraph as option for indication of Liquid Level.

Measuring principle

Capacitive level measurement is based on the change in capacitance of the capacitor due to the change in the level. A capacitor is formed when a level sensing electrode is installed in a vessel. The metal rod/electrode acts as one plate of the capacitor and the reference tube acts as the other plate.

As level rises, the air or gas normally surrounding the electrode is displaced by material having a different dielectric constant. A change in the value of the capacitor takes place because the dielectric between the electrodes has changed.

Capacitance instruments detect this change and convert it into a proportional output signal.

Function

The electronic insert of the probe converts the measured change in capacitance of the liquid to a signal in proportion to the level (4 to 20 mA) making it possible to display/control and/or regulate the liquid level when used in conjunction with a controller.

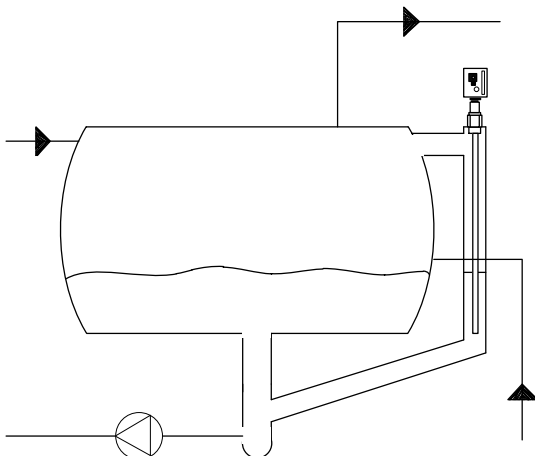

NOTE!
To avoid accumulation of oil in the stand pipe a 10deg. slope on connection pipe is recommended.

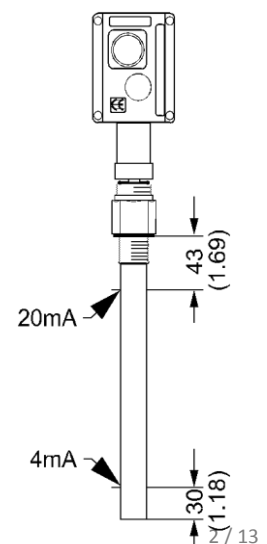

Technical data

Supply voltage and load:

24 V AC/DC $\pm 10\%$ (50/60Hz)
1.5 W

Signal output: 4-20 mA

Liquid refrigerants:

HBLT supports the following refrigerants

R717 (NH₃)* (factory setting)

R22

R404A

R134a

R744 (CO₂)

R718 (H₂O)*

*R717 and R718 will give the same output

Liquid temperature range:

-60/+120°C (-76/+248°F)

High temperature version +160°C (+320°F)*

EMC Test:

EMC Emission EN61000-3-2

EMC Immunity EN61000-4-2

Pressure range:

Max. working pressure: 100 bar (1450 psig)

Max. load resistance: 500 ohm

Ambient temperature:

During operation: -25 to +50°C (-13/+122°F).

During transport: -40 to +70°C (-40/+158°F).

Enclosure: IP65

Connection: 4-pole plug (DIN 43650)

Material:

Thread: Stainless steel. AISI 303

Reference pipe: Stainless steel. AISI 304

Inner electrode: PTFE

Electronic top part: coated cast aluminium



NOTE!

NOTE! When used in refrigerants with **temperatures above +60°C (140°F)** (e.g. heat pump applications) a **minimum calibration must be carried out after 1 week of operation**. Subsequently a min. calibration once a year is needed (see how to do so below).

To achieve the best accuracy when used in the **refrigerants R22, R404A, R134A and R744** a min. (0%) calibration **must** be carried out after 1 week of operation.

Design and function

Electronics

The sensor transmits a current signal from 4 to 20 mA (4 mA when the transmitter does not register liquid - and 20 mA when the entire transmitter is surrounded by liquid).

The electronic head and sensor tube can be separated by hand without emptying the vessel/standpipe. This allows installation of the sensor tube and later mounting the electronics or easy replacement if needed.

Sensor tube

The tube consists of two pipes. An outer reference tube and an inner PTFE insulated rod.

As the liquid will flow up between the rod and the reference tube the electrical capacitance throughout the length of rod immersed in the liquid is registered.

Factory setting

The HBLT comes factory calibrated for R717 (NH₃), so that it will cover 4 to 20 mA throughout the rod's whole measuring range. (4 mA when the transmitter does not register liquid and 20 mA when the entire transmitter is surrounded by liquid).

Any disturbances in connection with the level measurement will be damped internally.

For refrigerants: R717 (NH₃) / R718 (H₂O) it is **not necessary** to change the settings. The factory setting can be used.



NOTE!

For use in R22 / R404A / R134a / R744 (CO₂) setting for the required refrigerant **must** be made. Follow the procedure described in next section. If an alternative refrigerant other than the listed is used, a new calibration of the level transmitter is required.

Please observe that when used in R718 (H₂O), over time a lime coating on the outer reference pipe can be experienced. It is recommended to remove this coating on a regular basis.

Installation instruction

Mount the sensor tube in a standpipe or vessel with 3/4" NPT respectively 1" BSP thread connection.

When installed on an ammonia installation and the sensor has the appropriate length just apply power and the transmitter is in operation.

If the transmitter is to be used for level detection in other refrigerants than ammonia, please follow the 'setting of refrigerant'



NOTE!

When designing the stand pipe please make sure to create a slope on the connection pipe. This prevents accumulation of oil

Electrical connection

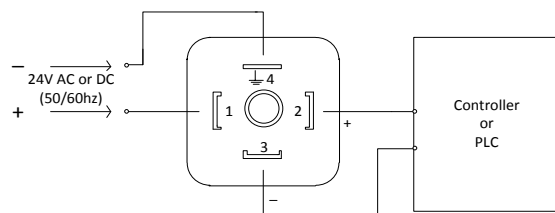

Setting of refrigerant

For refrigerant: R717 (NH₃) / R718 (H₂O) it is **not necessary** to change the settings. The factory setting can be used.

For settings for all other refrigerants or in case the electronics has been replaced, follow below procedure:

The setting may be carried out on start up.
Review also 'practical calibration hints' in this instruction manual.

1. To get in the refrigeration mode setting push the calibration pushbutton and keep it pressed while 24 V/plug is connected and then release the pushbutton.
2. Release the calibration pushbutton.

Observe the present refrigerant setting and measure the 4-20 mA output signal.

- 1 flash of Green LED - output signal is
~ 5 mA = R717 or R718 (factory setting)
- 2 flashes of Green LED - output signal is
~ 6 mA = R22
- 3 flashes of Green LED - output signal is
~ 7 mA = R404A
- 4 flashes of Green LED - output signal is
~ 8 mA = R134a
- 5 flashes of Green LED - output signal is
~ 9 mA = R744

3. Activate the calibration pushbutton to select required refrigerant.

Each activating will cause the HBLT to step to next refrigerant according to below sequence:

- ~ 5 mA = R717 or R718 (factory setting)
- ~ 6 mA = R22
- ~ 7 mA = R404A
- ~ 8 mA = R134a
- ~ 9 mA = R744

4. When the current corresponds to the required refrigerant, wait 10 seconds until the green LED is constant ON (not flashing). This indicates that the required refrigerant has been selected.

5. To leave the setting mode isolate the voltage supply to the level transmitter (disconnect plug from transmitter)

Go through step 1, 2 and 5 if you wish to control the setting.



NOTE!

This sequence must be observed:

If the supply voltage is connected before the calibration pushbutton is activated, the signal damping will be changed

Signal damping

Signal damping is factory set to 15 seconds. This setting can be altered by activating the calibration switch. The setting range is 1 to 120 seconds. Settings can be made whilst the system is operating

Procedure:

1. Connect the supply voltage.
2. Push the calibration pushbutton once for each second by which you want to increase the damping.

Example:

- | | | | | |
|-----------|----------|----|-------------|------------|
| 1. push | ⇒ 1 sec. | .. | 120. pushes | ⇒ 120 sec. |
| 2. pushes | ⇒ 2 sec. | | 121. pushes | ⇒ 120 sec. |

10 seconds after the last push, the value will be saved in the memory and the green LED will start flashing again. After 10 seconds, a further push will start 1-second signal damping again.

(If the damping setting is set too high, restart the procedure from step 1).

Calibration

HBLT will not need calibration if it is installed in R717 (NH₃) and the ordered length corresponds to actual liquid measuring range. Review also 'practical calibration hints' in this instruction manual.

Calibration of HBLT may be relevant:

- If the default setting does not fit and the min./max. calibration points have to be adjusted.
- If the HBLT is used in a liquid, not already specified
- If the electronic head is replaced on an existing HBLT transmitter (rod).

Usually the min. calibration point is chosen to be 4 mA and the max. calibration point to be 20 mA, but it is also possible to calibrate the transmitter at other calibration points.

This opportunity can be useful when calibrating on a plant with no possibility of bringing the level to the limit points.

Default factory setting is:

0% (HBLT free of liquid) output signal: 4 mA

100% (HBLT fully covered by liquid) output signal: 20 mA

The max. /min. points can be set to any value.

Adjusting the min and max calibration points



NOTE!

Max. calibration is only required if in other refrigerants than ammonia best possible accuracy is required alternative if a non pre-calibrated electronic part is mounted!

Min. calibration:

1. Bring the liquid level to desired minimum level.
2. Press the calibration pushbutton and keep it activated in approx. 5 seconds, until green LED stops flashing.
3. Activate, within the next 10 seconds, the calibration pushbutton once

Green LED is ON in a few seconds, and then starts flashing.

Output is now **4 mA** and the HBLT is in normal operation.

Max. calibration:

1. Bring the refrigerant liquid level to desired maximum level.
2. Press the calibration pushbutton and keep it activated in approx. 5 seconds, until green LED stops flashing.
3. Activate, within the next 10 seconds, the calibration pushbutton two times, with 1 second in between

Green LED is ON in a few seconds, and then starts flashing.

Output is now **20 mA** and HBLT is in normal operation.



NOTE!

If calibration button is not activated within 10 seconds, it will automatically leave calibration mode and return to normal operation.



NOTE!

Below calibration procedure is only to be followed if the minimum/maximum level must be different from 4/20mA

Min. calibration when minimum level must be different from 4 mA:

1. Bring the liquid level to desired minimum level.
2. Press the calibration pushbutton and keep it activated in approx. 5 seconds, until green LED stops flashing.
3. Activate, within the next 10 seconds, the calibration pushbutton once and keep it activated. (If calibration pushbutton is not activated within 10 seconds, it will automatically leave calibration mode and return to normal operation)
4. Observe the output mA signal increasing fast starting at 4 mA.
5. Release the calibration pushbutton when the output signal is approx. 0.5 mA from the desired point.
6. All the next activations will increase the output signal by approx. 0.05 mA
7. Approx. 10 seconds after the latest activation the LED starts flashing
8. Output now corresponds to the value measured at the latest activation.

Max. calibration when maximum level must be different from 20 mA:

1. Bring the liquid level to desired maximum level.
2. Press the calibration pushbutton and keep it activated in approx. 5 seconds, until green LED stops flashing.
3. Activate, within the next 10 seconds, the calibration pushbutton two times, with 1 second in between, and keep it activated. (If calibration pushbutton is not activated within 10 seconds, it will automatically leave calibration mode and return to normal operation)
4. Observe the output mA signal decreasing fast starting at 20 mA.
5. Release the calibration pushbutton when the output signal is approx. 0.5 mA from the desired point.
6. All the next activations will decrease the output signal by approx. 0.05 mA
7. Approx. 10 seconds after the latest activation the LED starts flashing
8. Output now corresponds to the value measured at the latest activation.

Reset to factory setting

The HBLT can always be reset to factory default setting regardless of any revised calibration values.

1. Press the calibration pushbutton and keep it activated in min. 20 seconds, until green LED starts flashing.
2. Release the calibration pushbutton.
3. When LED starts flashing, reset to factory setting is completed.

LED indication

When voltage is applied the LED will flash rapidly as many times as it has been calibrated through its lifetime. The current mA output is activated as soon as the flashing sequence has changed from rapid to slowly flashing.

Normal operation:

At normal operation the Green LED will be flashing slowly.

Generally the Green LED is ON every time calibration pushbutton is activated.

Calibration mode:

In calibration mode (Press the calibration pushbutton and keep it activated in approx. 5 seconds) the Green LED is OFF.

Change of refrigerant:

In refrigeration mode setting (Push the calibration pushbutton and keep it pressed while 24 V is connected and then release the pushbutton) the green LED is OFF until the pushbutton is released.

After this the green LED will flash according to the type of refrigerant.

When the refrigerant has been selected, the green LED is constantly ON.

Ordering codes

Ordering code	With bargraph	Length (100xmm)	Thread type 1" BSP	Description
HBLT-A1	(+B)	2,8	-	Length 280mm/Range 207mm (11.02"/8.1")
HBLT-A1	(+B)	5	-	Length 500mm/Range 427mm (19.69"/16.8")
HBLT-A1	(+B)	8	-	Length 800mm/Range 727mm (31.5/28.6")
HBLT-A1	(+B)	10	-	Length 1000mm/Range 927mm (39.37"/36.50")
HBLT-A1	(+B)	12	-	Length 1200mm/Range 1127mm (47.24"/44.4")
HBLT-A1	(+B)	15	-	Length 1500mm/Range 1427mm (59.06"/56.2")
HBLT-A1	(+B)	17	-	Length 1700mm/Range 1627mm (66.93"/64.1")
HBLT-A1	(+B)	22	-	Length 2200mm/Range 2127mm (86.61"/83.7")
HBLT-A1	(+B)	30	-	Length 3000mm/Range 2927mm (118.1"/115.2")

Ordering code	With bargraph	Length (inch)	Thread type 3/4"NPT	Description
HBLT-A1	(+B)	6	U	Length 6"/Range 3.13" (152mm/79mm)
HBLT-A1	(+B)	8	U	Length 8"/Range 5.13" (203mm/130mm)
HBLT-A1	(+B)	12	U	Length 12"/Range 9.13" (305mm/232mm)
HBLT-A1	(+B)	15.3	U	Length 15.3"/Range 12.43" (389mm/316mm)
HBLT-A1	(+B)	19.2	U	Length 19.2"/Range 16.33" (488mm/415mm)
HBLT-A1	(+B)	23.1	U	Length 23.1"/Range 20.23" (587mm/514mm)
HBLT-A1	(+B)	30	U	Length 30"/Range 27.1" (762mm/689mm)
HBLT-A1	(+B)	35	U	Length 35"/Range 32.1" (889mm/816mm)
HBLT-A1	(+B)	45	U	Length 45"/Range 42.1" (1143mm/1070mm)
HBLT-A1	(+B)	55	U	Length 55"/Range 52.1" (1397mm/1324mm)
HBLT-A1	(+B)	65	U	Length 65"/Range 62.1" (1651mm/1578mm)
HBLT-A1	(+B)	85	U	Length 85"/Range 82.1" (2159mm/2086mm)
HBLT-A1	(+B)	105	U	Length 105"/Range 102.1" (2667mm/2594mm)
HBLT-A1	(+B)	120	U	Length 120"/Range 117.1" (3048mm/2974mm)

Ordering code examples

HBLT-A1-5 ->

1" BSP threaded 500mm level transmitter without bargraph

HBLT-A1B-30U ->

3/4"NPT threaded 30" level transmitter **with** bargraph

Practical calibration hints

All HBLT Level Transmitters are pre calibrated to ammonia. Giving 4 mA out when no ammonia liquid is surrounding the HBLT and when it is fully submerged by ammonia liquid, it will give a 20 mA output signal.

The electronic top part of HBLT can be separated from sensor tube.

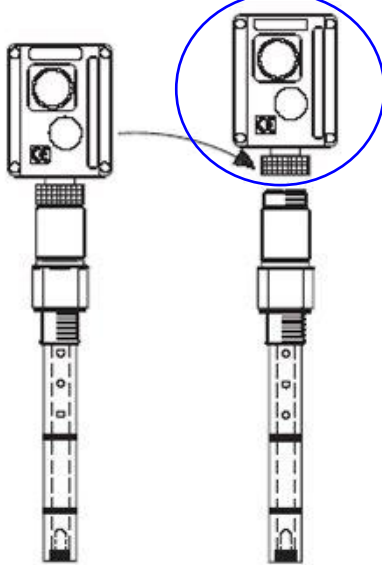

Ordering codes for electronics:
 HBLT-A1 without bargraph
 HBLT-A1B with bargraph

If a new HBLT electronics has to be installed on an existing sensor tube, the electronics must always be calibrated.

All replacement electronics are pre calibrated to ammonia and a sensor tube length of: 1500 mm/59"
 When installed on all other lengths (than 1500mm/59") it has to be calibrated on site.

Please observe calibrated means that a min. point (normally 4 mA) and a max. point (normally 20 mA) has to be set.

If the transmitter has to be calibrated on the plant it would normally be possible to empty the standpipe for liquid and enter the Min. point (4 mA).
 In most cases it is however almost impossible to get the refrigerant liquid to the desired maximum level to calibrate the Max. point (20 mA).

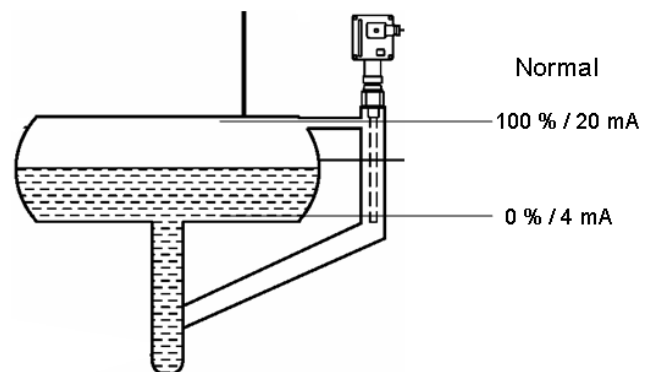

Furthermore it is a problem to see the liquid level when the level signal from the level transmitter cannot be used. Some sight glasses may be present, but it is seldom that it covers the lower or the upper part of the rod.

How to do Max calibration on ammonia installation on site

Ammonia and water does have the same properties with respect to capacitive measurements. This is very convenient as water off cause in much easier and safer to deal with. So in general if the HBLT is submerged into water it will generate the same signal as if it where ammonia.



PLEASE OBSERVE!

Calibration in water means that HBLT subsequently is set for ammonia.

Long probes

If it is a long probe (eg. 3m/120") it can be difficult to get hold of a pipe that long and then fill it up with water for doing the max calibration.

A work around of this problem can be:

- 1) Turn HBLT upside down
- 2) Tighten all holes in the reference pipe with tape.
- 3) Fill the pipe with water according to your calibration needs. With the reference pipe full of water a max. calibration can be carried out.

Please observe that the 4-20 mA output signal is not inverted despite the upside down position

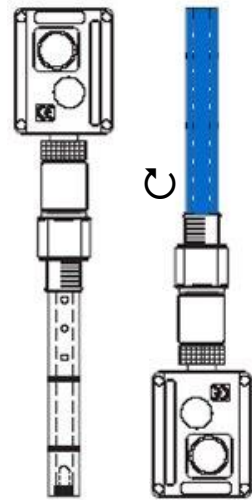

Replacing/mixing top part on different sensor probes

In service situation it can sometimes be necessary to install an HBLT electronics that does not match the sensor probe in terms of length or refrigerant.

Factory reset of HBLT electronics

A factory reset can always be carried out regardless how the HBLT has been operated. Check 'reset to factory setting' to see how. A factory reset will always force the HBLT to go back to below settings:

- refrigerant : ammonia
- sensor length: 1500 mm/59"
- signal damping : 15 seconds

Installing a new HBLT electronics with ammonia as refrigerant

As all new electronics are calibrated to ammonia with a sensor length of 1500 mm/59" it must in all other cases be calibrated. The following procedure is to be followed:

- 1) Install HBLT electronics and connect power
- 2) Make sure that HBLT sensor probe is free of liquid and carry out Min. calibration.
- 3) Make sure that HBLT sensor probe fully submerged by ammonia liquid and carry out Max. calibration.
- 4) If 3) is not possible use above 'upside down' method

Installing a new HBLT electronics with a refrigerant other than ammonia

The following procedure can be used:

- 1) Install HBLT electronics and connect power
- 2) Make sure that HBLT sensor probe is free of liquid and carry out min. calibration.
- 3) Make sure that HBLT sensor probe is fully submerged by ammonia liquid and carry out Max. calibration.

ONLY if 3) is not possible, then:

- a) Remove complete sensor probe out of stand pipe.
- b) Install new HBLT electronics on sensor probe. Please observe that a new electronics always are factory set to ammonia!
- c) Turn HBLT upside down
- d) Tighten the holes in the outer reference pipe with tape
- e) Install HBLT electronics and connect power and a mA-meter
- f) Carry out Min. calibration
- g) Fill the HBLT completely with water
- h) Carry out max. calibration
- i) Disconnect power.
- j) Remove the tape from the holes.
- k) Change refrigerant to the actual refrigerant used on the plant.
- l) Clean and dry HBLT pipe for water and reinstall HBLT in the vessel/standpipe.

High refrigerant temperature

When installed in high temperature application (e.g. heat pump applications) calibration must be fulfilled on regular basis. Only a min. calibration is recommended.



NOTE!

When used in refrigerants with **temperatures above +60°C (140°F)** a Min./Max Calibration **must** be carried out after 1 week of operation. Subsequently only a min. calibration once a year is needed.

Check of sensor tube

Eventually check of the sensor tube, can be done without removing the sensor tube from the standpipe/vessel.

Remove the HBLT electronics and connect an isolation tester (MOhm meter) as shown.

The reading should be in the range from 1 MOhm to 10 GOhm or infinity, if the reading is lower than 1MOhm the sensor tube is defect.

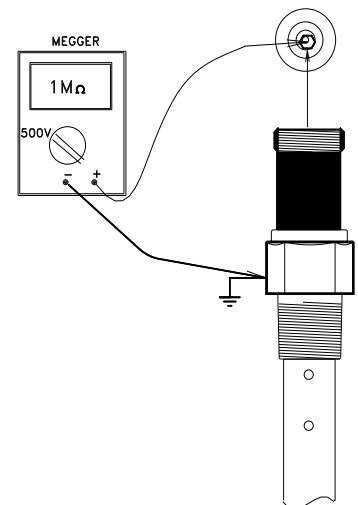

Trouble shooting

Symptom	Cause	How to detect/repair defect
No function	No supply voltage Wrong supply voltage	Check power supply and connection cable
It takes a long time after power up before the 4-20 mA signal is updated	Min./Max calibration has been carried out several times on site.	After power up the green LED flashes rapidly as many times as it has been calibrated through its lifetime. First after this green LED flashes changes to slowly the 4-20 mA is updated
4-20 mA output signal is to low	Oil has been accumulated in the standpipe. Oil falls to the bottom on ammonia systems	Drain oil out of standpipe. If a very big amount of oil is present it may be necessary to take out the sensor rod and clean it for oil
No 4-20 mA output	Not wired correctly	Green LED continues to flash rapidly. If 24 AC/DC supply: Check polarity
4-20 mA signal does not correspond to actual liquid level	Wrong refrigerant selected	Set correct refrigerant.
No 4-20 mA output and green LED is OFF	Electronics defect	Replace HBLT electronics
4-20 mA signal does not correspond to actual liquid level	Operator has calibrated wrongly	Fulfil a factory reset

Further information

For further information please check our website www.hbproducts.dk or send an e-mail to: support@hbproducts.dk

DECLARATION OF CONFORMITY

We

HB Products A/S

declare under our sole responsibility that the products:

Category: Instrumentation
Type: HBLT-A1 liquid level transmitter

Description: Level sensors based on capacitive principle
Make: Developed and produced by HB Products A/S

to which this declaration relates is in conformity with the standards noted below:

EN 61000-3-2 EMC General Emission Requirements
Industrial Environment

EN 61000-3-2 Electromagnetic compatibility – Generic emission standard – Part 2: Industrial environment

EN 61000-4-2 EMC General Immunity Requirements
Industrial Environment

EN 61000-4-2 Electromagnetic compatibility – Generic immunity standard – Part 2: Industrial environment

Following the provision of European directives:

89/336/EEC Electromagnetic Compatibility

Date: 10th May 2011

Signed: 

Name: Michael Elstrøm
Managing and Technical Director